

Lightvision

A publication of Lightwaves2020 May, 9, 2011

PBS/PBC & PC in Coherent Communication System

Polarization Division Multiplexing (PDM) plays an important role in next generation high data-rate communication systems. Principally, optical light with different polarization states is capable of carrying different signals to increase the transmitted data rate. In order to control the polarization states in the fiber-optical transmission system, Polarization Beam Splitter/Polarization Beam Combiner (PBS/PBC) and Polarization Controller (PC) are three indispensable components. PBS/PBC is utilized for polarization diversity receivers and is also essential for polarization shift keying systems. By using PBS/PBC, signals with different polarizations can be modulated on the transmitter side and then demodulated on the receiver side. On the other hand, PC is to make sure the optical signal passed to the receiver is kept in the 45° direction relative to the optical axis. Figure 1 shows an example of typical high data-rate coherent communication systems with PBS/PBC and PC integrated. (1)

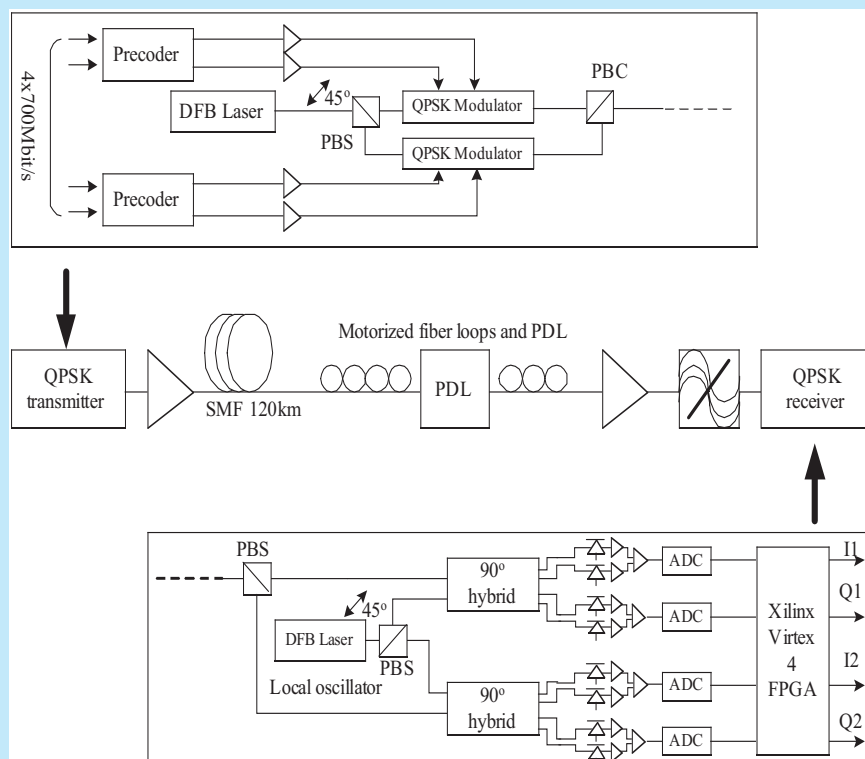

Figure 1: High Data-Rate Coherent System with PBS/PBC and PC integrated (1)

Lightwaves2020 pioneers in developing miniature polarization management components for years. In view of the increase in the demand for the PDM system, Lightwaves2020 releases the miniature wideband PBS/PBC with dimensions of 25mm x 15mm x 5mm. The operation wavelength range covers 1510-1610nm bandwidth and the polarization extinction ratio is > 22dB. Figure 2 shows the standard polarization orientation of PBS/PBC. Output fiber type can be SMF or PMF.

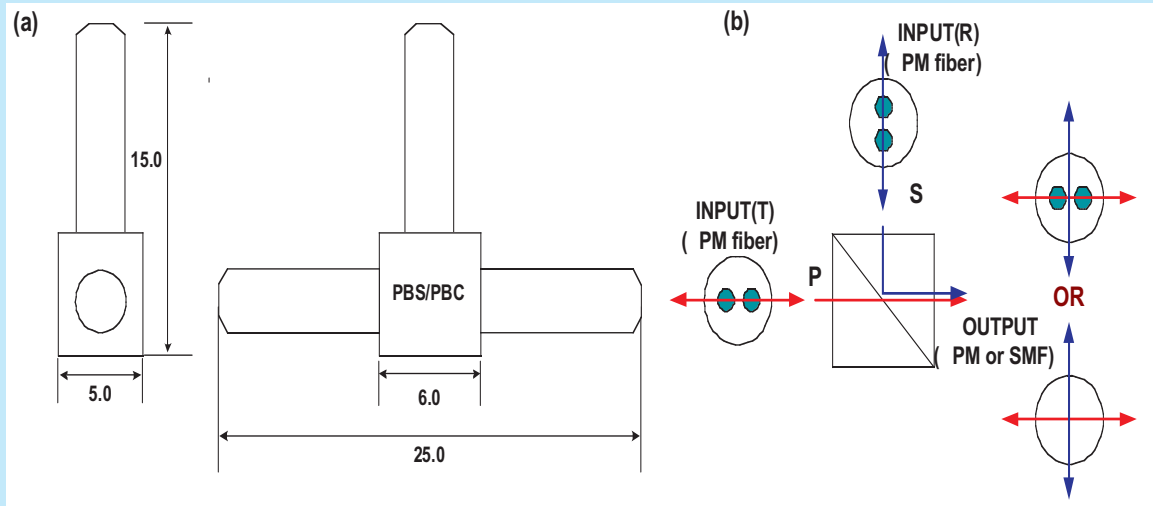

Figure 2: PBS/PBC Devices (a) Outline; (b) Polarization Orientation

Different from PBS/PBC, the speed and long-term operation reliability for PC is very important since it is an active device. Currently, Lightwaves2020 provides High-Speed PC (HS-PC) with ms order response speed which is the best candidate for high data-rate coherent communication systems. Furthermore, the second generation HS-PC is ready for release with two key improvements, hermetical sealing process and ultra-small mini DIL package (dimensions: 13.8mm x 8.0mm x 7.3mm). TEC is also included inside the new package. Hermeticity guarantees the device reliability and smaller package size provides more design freedom for the users to integrate this component into their system.

In order to provide the market with the best solution based on system consideration, Lightwaves2020 is capable of all sorts of custom designs, especially for the polarization management components. Please contact us if you need any future support.

Reference:

(1) Pfau, T.; Peveling, R.; Hauden, J.; Grossard, N.; Porte, H.; Achiam, Y.; Hoffmann, S.; Ibrahim, S.K.; Adamczyk, O.; Bhandare, S.; Sandel, D.; Porrmann, M.; Noe, R.; "Coherent Digital Polarization Diversity Receiver for Real-Time Polarization-Multiplexed QPSK Transmission at 2.8 Gb/s," *IEEE Photonics Technology Letters*, vol. 19, no. 24, Dec. 2007





Beyond Bench-Top Laser Sources

One of the existing applications for fiber-based tunable laser sources is for test instrumentation where size is typically not a concern. Lightwaves2020’s popular compact High-Speed Tunable Filter (HS-TF) and compact amplified spontaneous emission (ASE) source technologies offer the option to produce very compact and module-sized tunable laser sources complimentary to numerous advantages highlighted in a prior Lightvision publication, the High Power Tunable Laser Source.

The Wide-Band option of such tunable laser source can be easily realized with Lightwaves2020’s C+L Band flat-top ASE technology in addition to the second nature feature of the HS-TF which is capable of covering tuning ranges over 100nm. Compared with the competition, Lightwaves2020’s solution offers a whole new level of capabilities listed in Table 1 showing also the technology source.

Above the Competition	Technology Source
High Tuning Resolution (25G, 12.5G, and beyond)	HS-TF
High Signal Clarity (Side-Mode Suppression Ratio >50)	HS-TF
High Tuning Speed (ms-order)	HS-TF
High Signal Power Stability (0.01dB/hr)	HS-TF
High Signal Power Output (13/15/17dBm options and greater)	ASE Source
High Signal Uniformity (±0.5dB)	ASE Source
Compact (module-sized)	HS-TF + ASE Source
Low Cost (fraction of large bench-top equipment)	HS-TF + ASE Source

Table 1: Capabilities and Technology Sources of WB-TLS

Coherent Communications Vision

With Lightwaves2020's line of polarization products, including the Polarimeter, HS-PC, and High-Speed Polarization Rotator, optical communications equipment customers are bracing the advantages of high capacity PDM applications. Lightwaves2020 offers these realities now and is breaking through new barriers to offer potential realities in the future. Currently, Lightwaves2020 is developing this Wide-Band Tunable Laser Source (WB-TLS) for the potential as a unified laser source for transmitters predominated by semiconductor laser modules. Aside from the low cost advantage, Lightwaves2020's fiber-based tunable laser source is capable of offering optical power, channel clarity, and capacity far beyond that of its semiconductor counterpart.

For optical transmission capacities far beyond Petabit systems where single carriers reach beyond 100G/s, PDM based coherent systems are becoming very essential. By incorporating Lightwaves2020's WB-TLS and HS-PC, capacity thus can be increased through three factors: quantity of signals, quantity of wavelength channels, and quantity of polarization states.

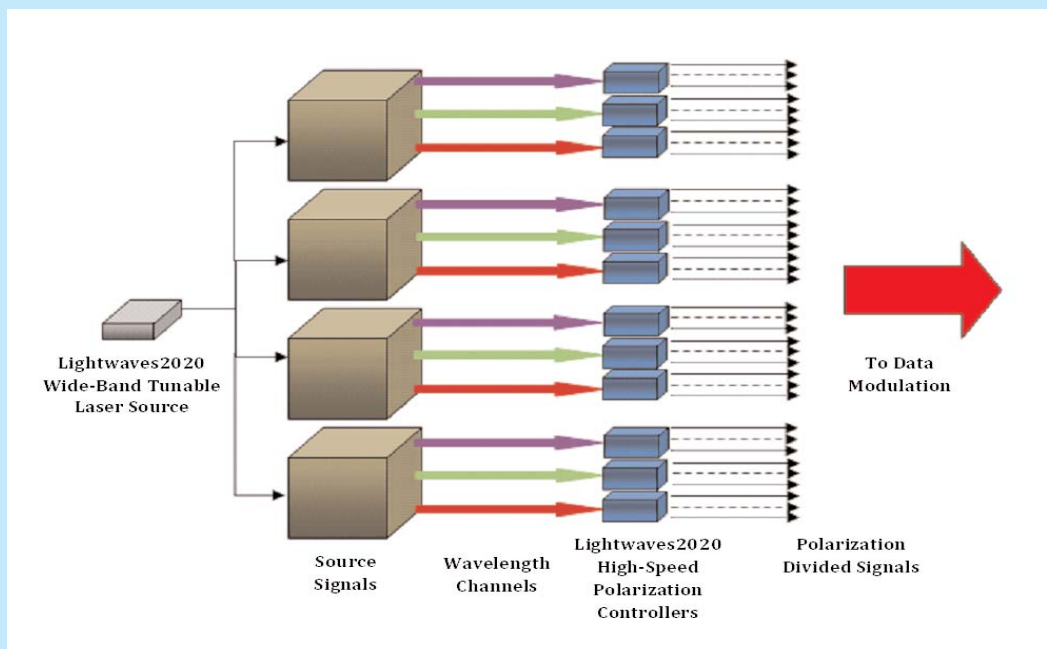

Figure 1: High Transmission Capacity with Multiple Wavelengths and Multiple Polarizations

The WB-TLS is potentially applicable to substitute the optical source in current communication system and offers superior flexibility and capacity added to the cost effective factor. It can be easily applied to high performance bench-top test instrumentation where manual or sweep tuning is at the user's fingertip. Beyond communication systems, sensor, military, and medical uses are certainly in high demand.



1323 Great Mall Drive, Milpitas, CA
95035-8037
Tel.408.503.8888 Fax. 408.503.8988
www.lightwaves2020.com
sales@lightwaves2020.com

Lightvision

Lightvision is a publication of Lightwaves2020 as a service to customers and sales associates. No part of this newsletter may be reproduced without the written consent of the publisher.

Editor Vivian Wang